

### ROTA-FLEX ROTARY INDEXER

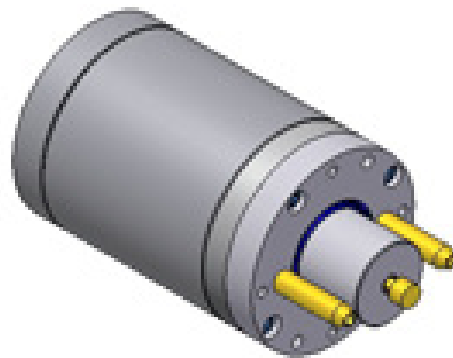

Rota-Flex is a positive locking mechanical indexer ideal for manual trunnions and dial tables. Rota-Flex is designed for flexible assembly pallet change over.

Provides low cost, secure, repeatable positioning in 30 degree increments. Consult factory for other increment options.

Spring loaded, self locking mechanism provides both positioning and safety functions.

Actuation options include: robot, manual tool, pneumatic foot pedal or hand button.

Tested for longevity and repeatability for 4.5 million indexes.

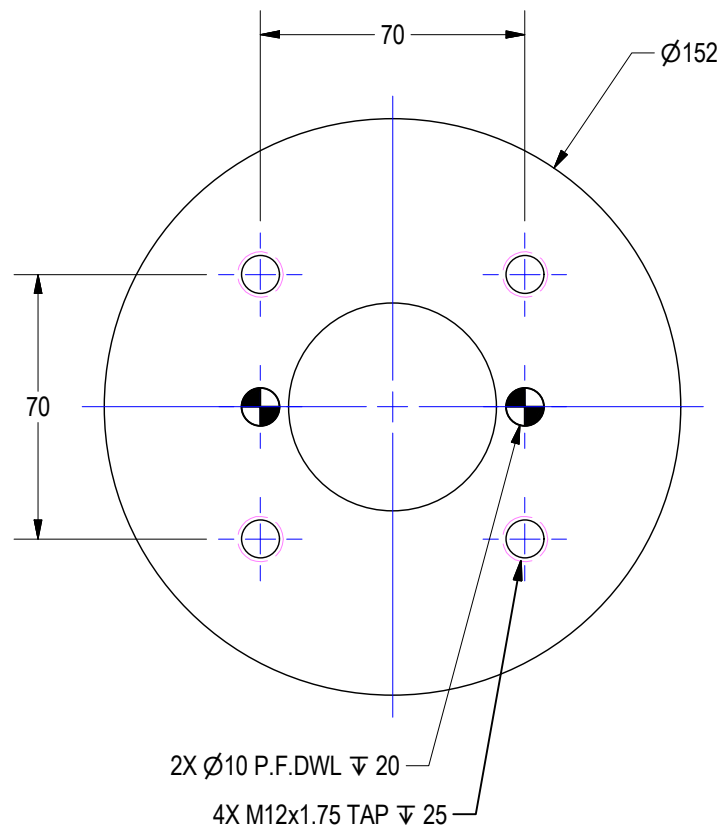

**ORDER AS: RF3**

**ROTA FLEX FEATURES:**

1. STEEL CONSTRUCTION
2. SEALED AND LUBED FOR LIFE
3. SELF LOCATING 30° INDEX
4. MINIMAL BACKLASH
5. HORIZONTAL OR VERTICAL APPLICATION
6. ACTUATION:
  1. ROBOT INDEX
  2. MANUAL PNEUMATIC INDEX OPTION
7. OPTIONAL MOUNTING BRACKET
8. OPTIONAL ROBOT INDEX TOOLING
9. FIXED AND ROTATING SIDES CAN BE REVERSED
10. UNIT WEIGHT 70 lbf
11. PATENT PENDING

**CAPABILITY SPECS:**

1. 400 Lb-Ft MAX TORQUE
2. REPEATABILITY TO +/-0.12mm [.005"] AT 300mm [12"] FROM CENTER

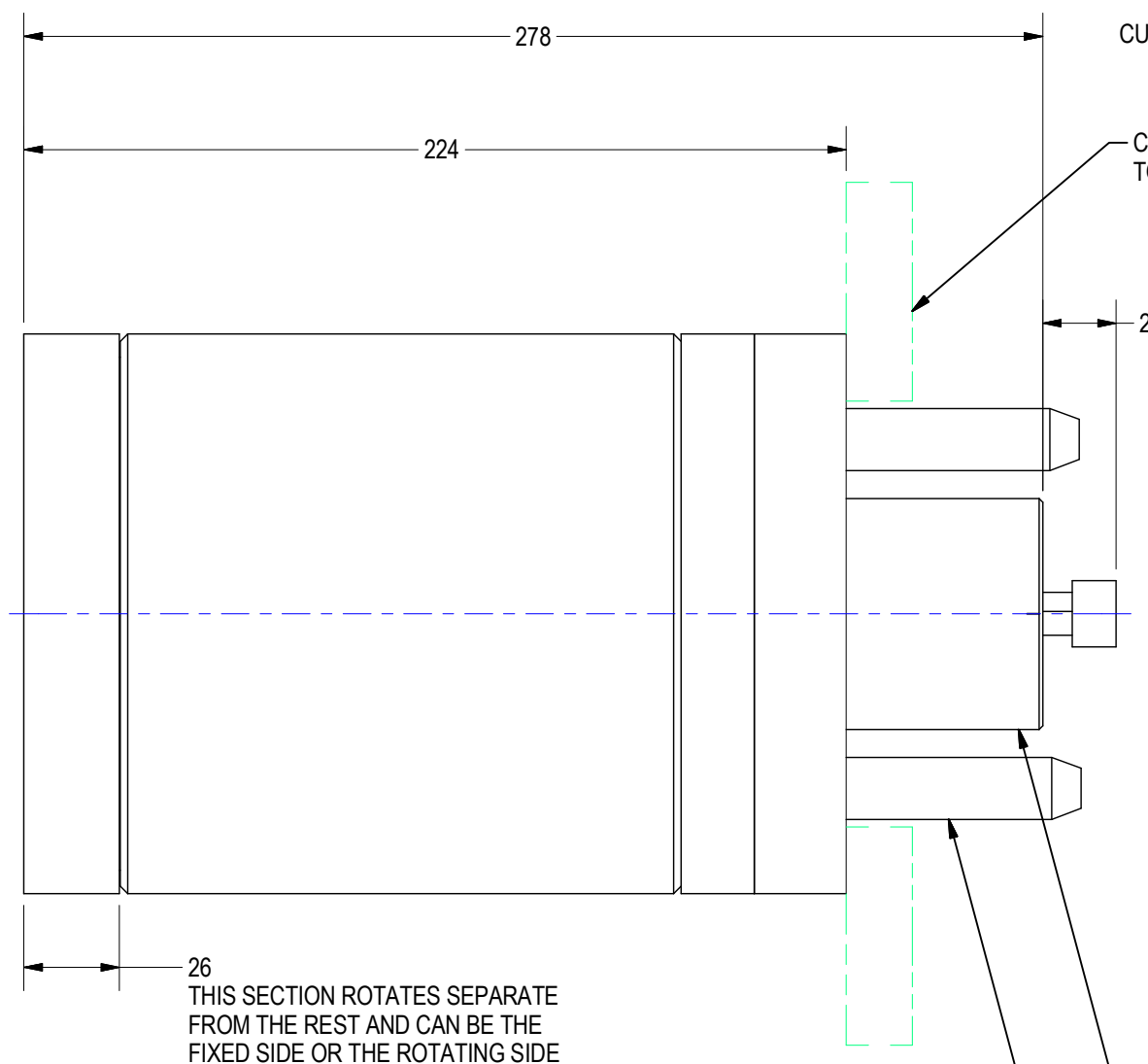

CUSTOMER SUPPLIED TOOLING PLATE

CUSTOMER SUPPLIED TOOLING PLATE

20

PUSH/RELEASE CAP  
MANUAL PNEUMATIC TOOL  
AVAILABLE FOR MANUAL ROTATE

2X ROTATE BOLTS FOR  
ROBOTIC ROTATION

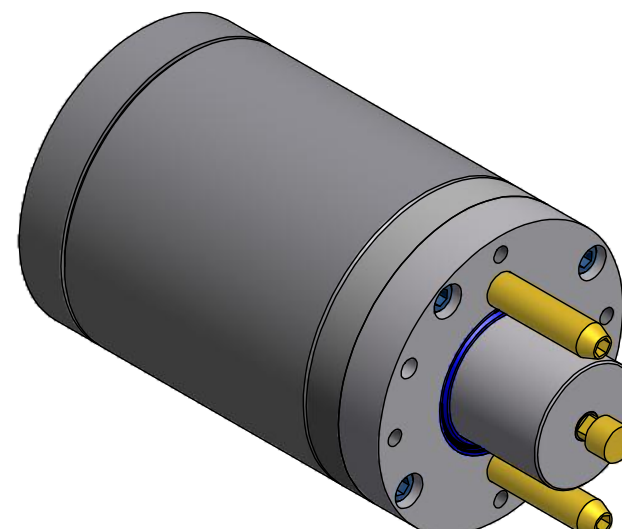
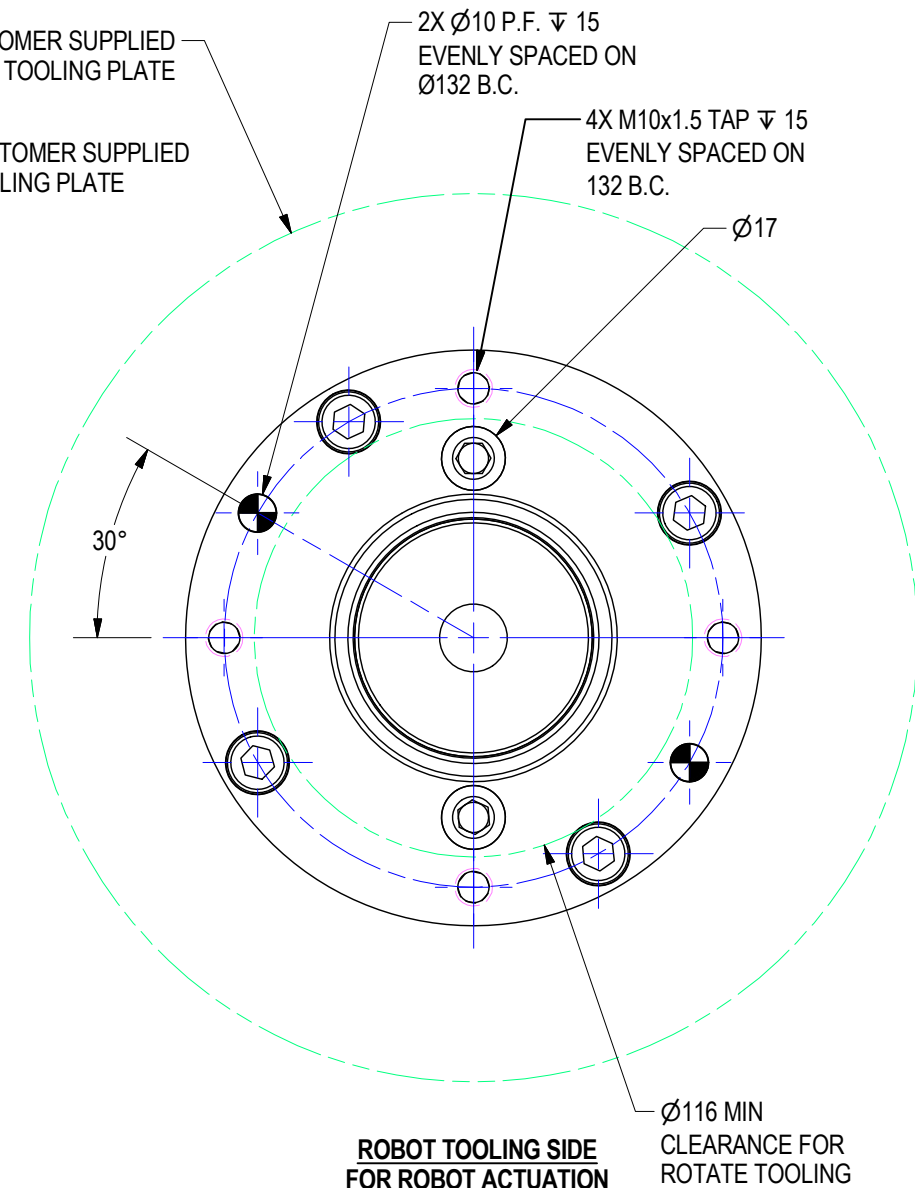

UNITS ARE MILLIMETERS  
(i.e. X.XXmm [x.xxx"])  
DO NOT SCALE DRAWING

DATE	STATUS	DRAWN BY	DATE	CHK'D BY	ENG APPROVAL
11/11/2008	Released	DJH	9/10/2008	DJH	
SCALE		1:4	FILE NAME		RF3L01

<b>WEKER</b> BEARING COMPANY					
TOOL NAME: ROTA-FLEX ASSEMBLY					
TEMPLATE					
DRAWN BY	DATE	CHK'D BY	ENG APPROVAL		
DJH	9/10/2008	DJH			
SCALE		1:4	FILE NAME		RF3L01

**ORDER AS: RF3M**

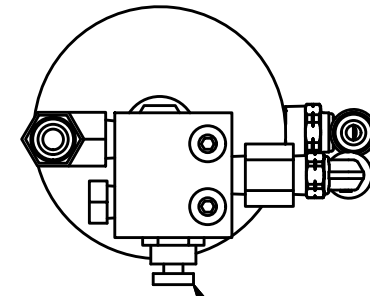

PUSH BUTTON FOR ACTUATION

STD 1/4" PNEUMATIC QUICK DISCONNECT

2 1/2" BORE AIR CYLINDER

Ø66.5 [2.62]

COUPLER RECEIVER POCKET

52.0 [2.05]

300.1 [11.82]

111.1 [4.38]

54.0 [2.13]

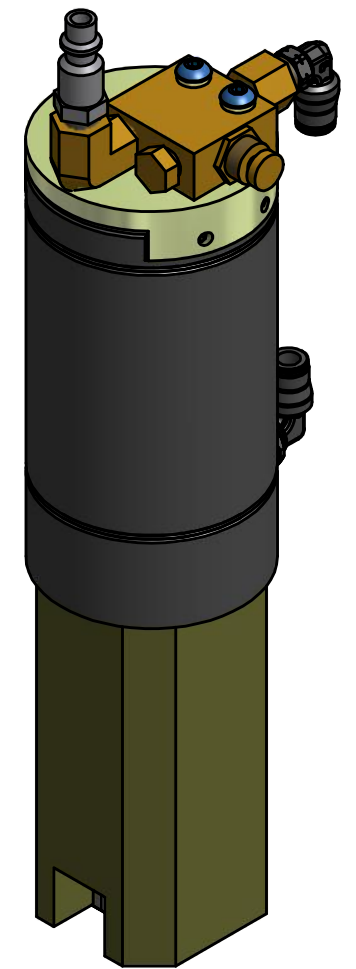

UNITS ARE MILLIMETERS  
(i.e.X.XXmm [x.xxx"])  
DO NOT SCALE DRAWING

<b>WEKER</b> BEARING COMPANY					
TOOL NAME PNEUMANUAL ASSY					
TEMPLATE					
DRAWN BY DJH	DATE 3/23/2009	CHK'D BY	ENG APPROVAL		
DATE 3/23/2009	STATUS Released	SCALE HALF	FILE NAME	RF3ML01	

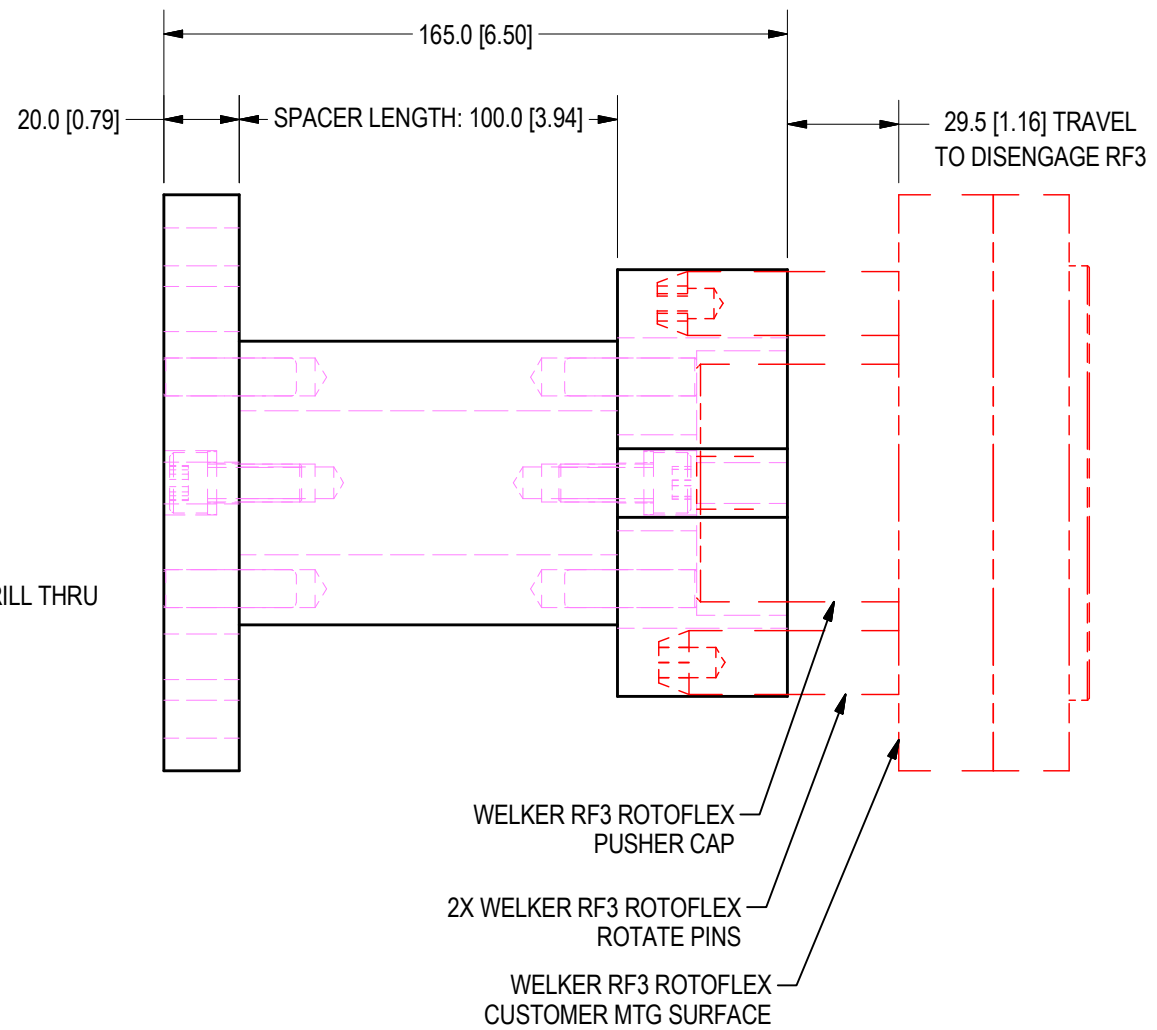
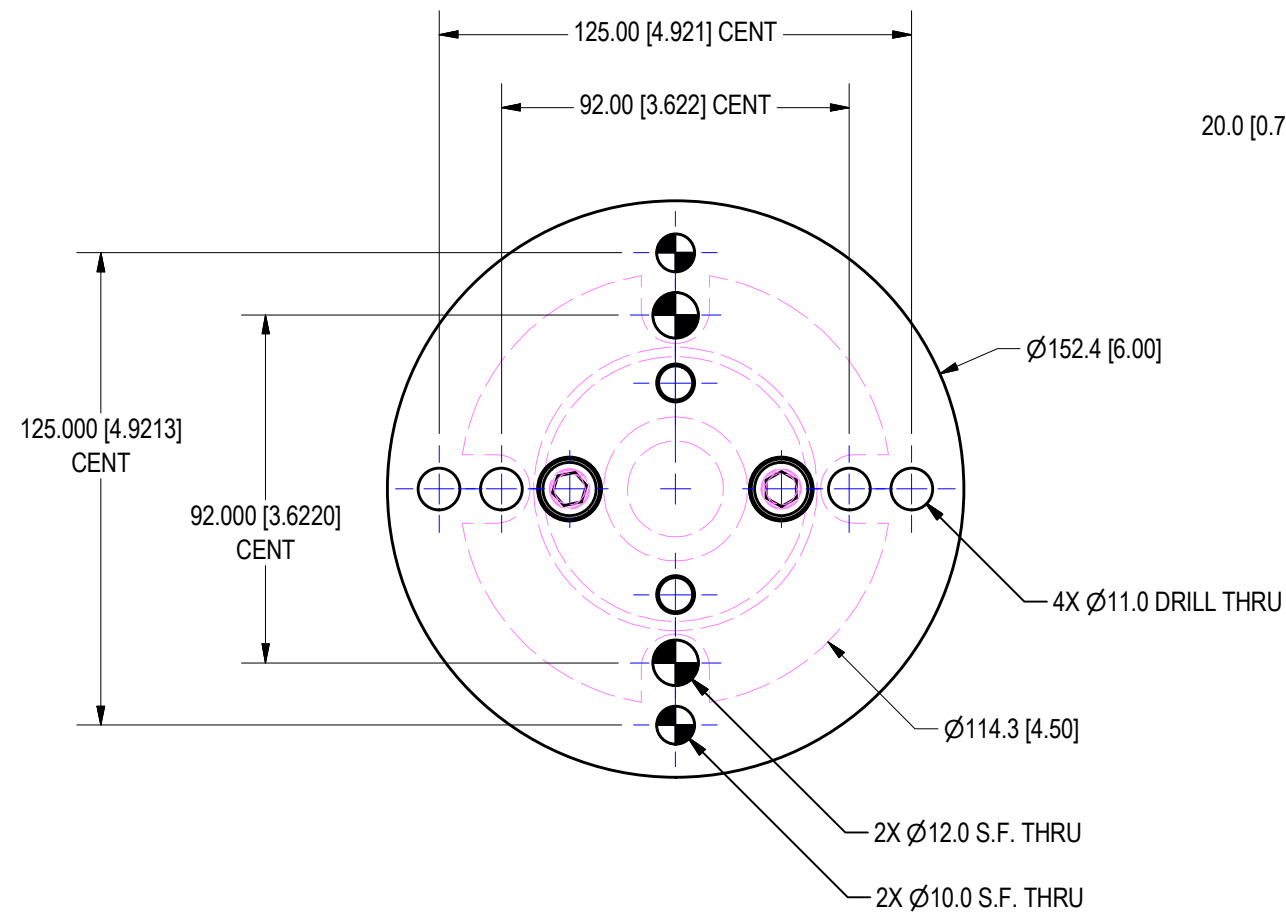

### ORDERING INFORMATION

**R F 3 R 1 0 0 X 0 1 0 0**

Series  
**RF4R**

Spacer Length  
**100** 100mm Standard Length  
(Custom lengths available)

Flange Style  
**01** Standard Flange Shown

FLANGE STYLE SHOWN FITS, BUT IS NOT EXCLUSIVE TO:  
FANUC ROBOT ISO FLANGE WRIST #210F, 100P  
KAWASAKI ROBOT FLANGE WRIST #UX100-120-150 & UT100-120-150

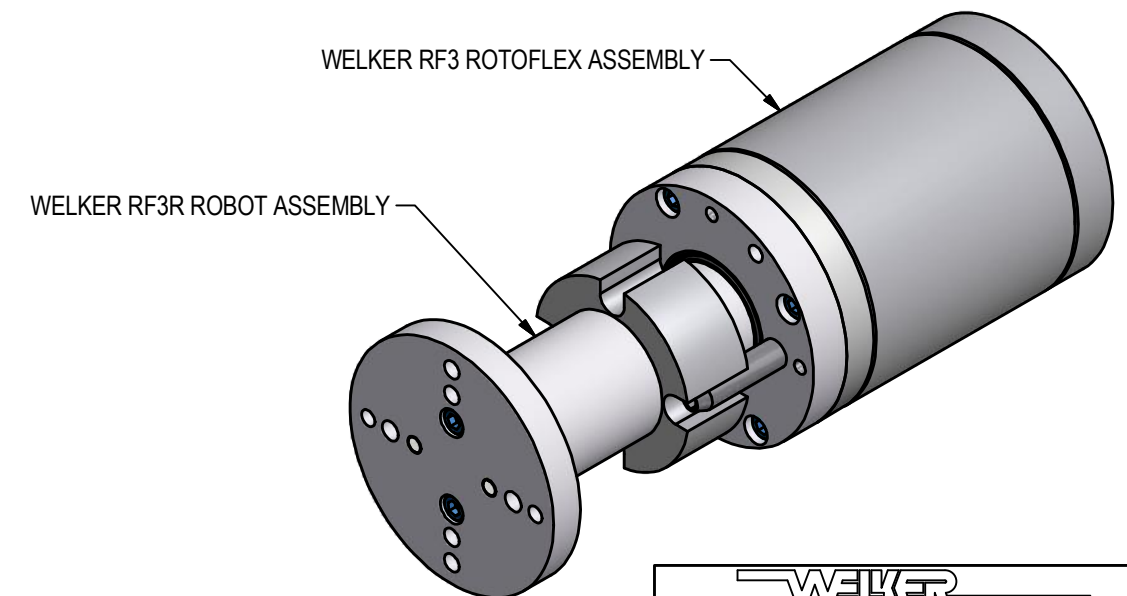

UNITS ARE MILLIMETERS  
(i.e.X.XXmm [x.xxx"])  
DO NOT SCALE DRAWING

WELKER BEARING COMPANY					
TOOL NAME					
ROBOT ROTATE TOOLING					
TEMPLATE					
DATE	STATUS	DRAWN BY	DATE	CHK'D BY	ENG APPROVAL
9/10/2008	Released	DJH	9/10/2008		
SCALE		FULL		FILE NAME	RF3RL01

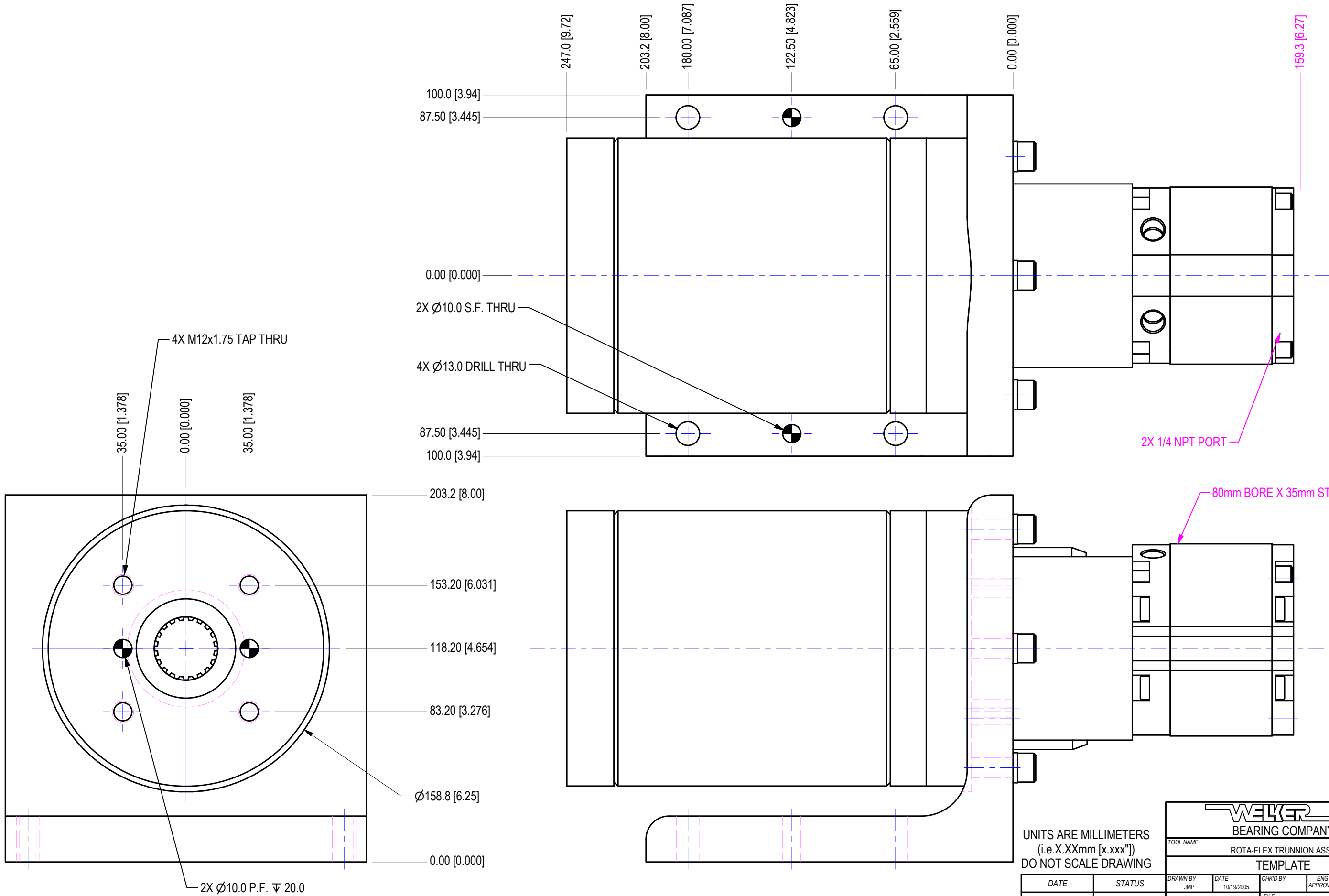

UNITS ARE MILLIMETERS  
(i.e.X.XXmm [x.xxx"])  
DO NOT SCALE DRAWING

DATE	STATUS	DRAWN BY	DATE	CHK'D BY	ENG APPROVAL
11/7/2008	Released	JMP	10/19/2005		
SCALE		1:2	FILE NAME		S01163L01

**WEKER BEARING COMPANY**

TOOL NAME: ROTA-FLEX TRUNNION ASSY

TEMPLATE